

PROJECT:

LOCATION:	ENGINEER:	SALES ENGINEER:
ARCHITECT:	CONTRACTOR:	DATE:

MODEL	'A'	'B'	'C'	MODEL	'A'	'B'	'C'
IAFE 6050	5'	6	9.80	IAFE 6100	10'	6	9.80
IAFE 8050	5'	8	12.43	IAFE 8100	10'	8	12.43
IAFE 6075	7.5'	6	9.80				
IAFE 8075	7.5'	8	12.43				

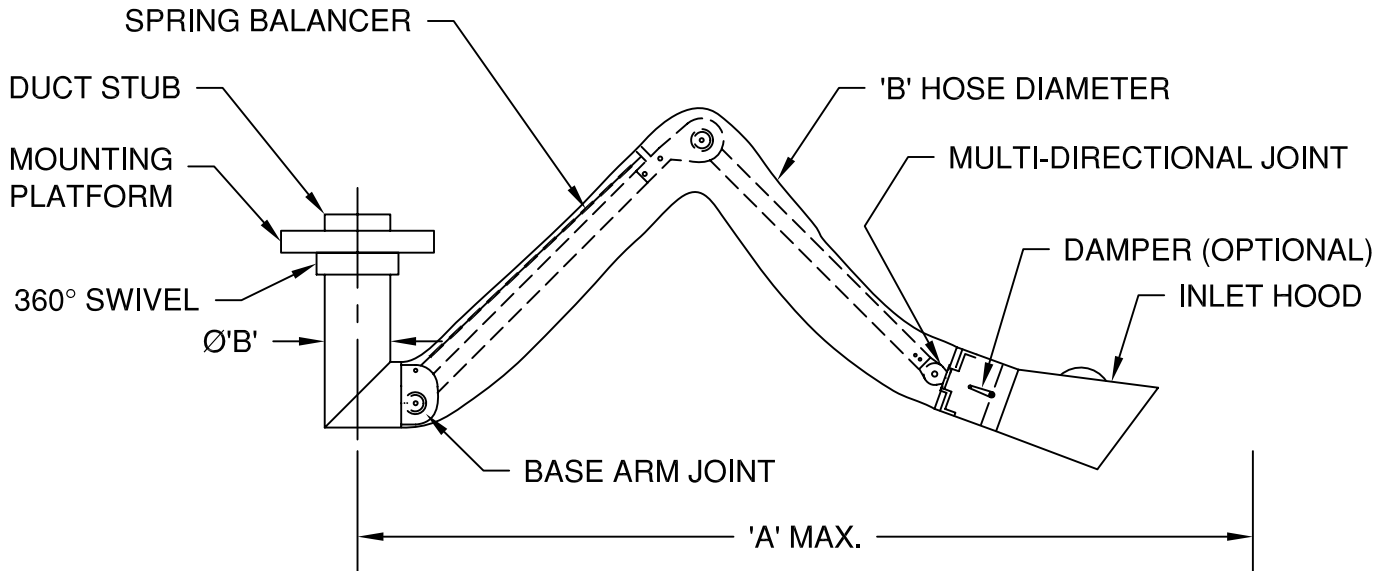
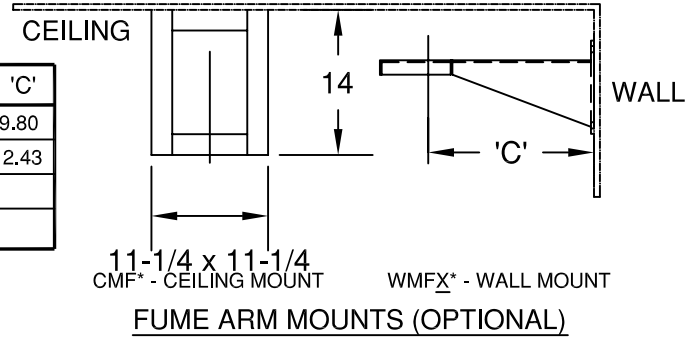

SCHEDULE

ITEM	QTY	MODEL	REFERENCE

NOTES:

ALL DIMENSIONS SHOWN IN INCHES.
 PLATFORM- 16 GA PAINTED STEEL. ARM TUBES- 1/8" WALL, SQUARE ALUMINUM. ARM JOINTS- 10 GA GALVANIZED STEEL. CEILING AND WALL MOUNTS- PAINTED STEEL.
 FLEXIBLE HOSE- MODEL NG NEOPRENE IMPREGNATED POLYESTER WITH GALVANIZED STEEL HELICAL SUPPORT. WELD HOOD- MODEL WH, 20 GA GALVANIZED STEEL.
 QUADRANT DAMPER AND/OR STAINLESS STEEL AND POLYCARBONATE CONSTRUCTION AVAILABLE. SPECIAL LENGTHS AND DIAMETERS MAY BE AVAILABLE UPON REQUEST.
 *SEE INDIVIDUAL SUBMITTALS FOR ADDITIONAL INFORMATION.