

PROJECT:

LOCATION:

ENGINEER:

SALES ENGINEER:

ARCHITECT:

CONTRACTOR:

DATE:

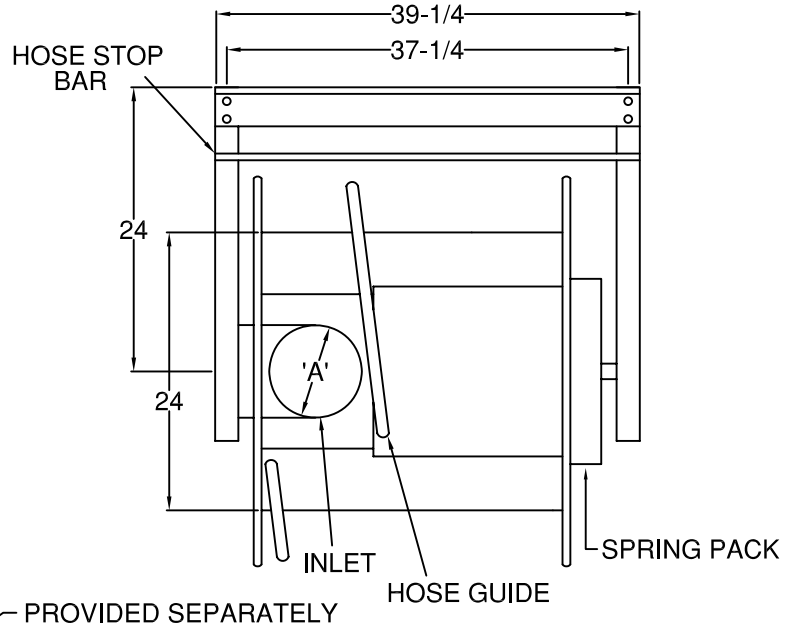
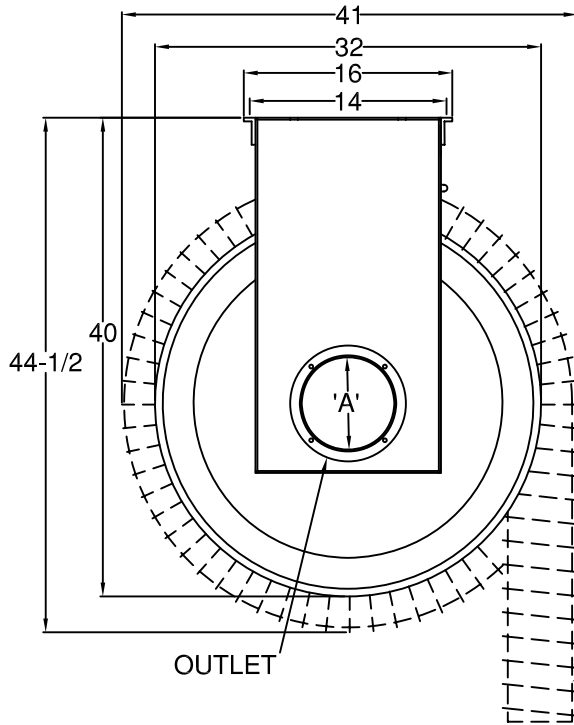

MODEL	HOSE DIAMETER 'A'	HOSE CAPACITY STD * (FT)
HRA800	8	25'

SPECIFICATIONS:

DRUM: 14 GA. GALVANIZED STEEL
 DRUM SIDE PLATE: 16 GA. GALVANIZED STEEL
 FRAME: 12 GA. GALVANIZED STEEL
 BEARING: SLEEVE BEARINGS
 LOCKING LATCH MECHANISM
 ADJUSTABLE HOSE STOP INCLUDED (NOT SHOWN)

OPTIONS:

MICROSWITCH FOR FAN/DAMPER CONTROL (MODEL MKS)
 FAN W/ MOUNT (MODEL FRM)

FOUR Ø1/2" MOUNTING HOLES IN 14" X 37-1/4" RECTANGULAR PATTERN

SCHEDULE

ITEM	QTY	MODEL	HOSE TYPE	HOSE DIAMETER	HOSE LENGTH	REFERENCE

NOTES

ALL DIMENSIONS IN INCHES UNLESS OTHERWISE SPECIFIED.
 ALL HOSE REELS COME WITH HOSE STOP RING AND PULL CABLE.
 EXHAUST ADAPTER, FLEXIBLE HOSE, FAN AND PULL CABLE SPECIFIED ON SEPARATE DRAWING.
 * CONSULT FACTORY FOR LARGER CAPACITIES OR NONSTANDARD DIAMETERS.