

PROJECT:

LOCATION:

ENGINEER:

SALES ENGINEER:

ARCHITECT:

CONTRACTOR:

DATE:

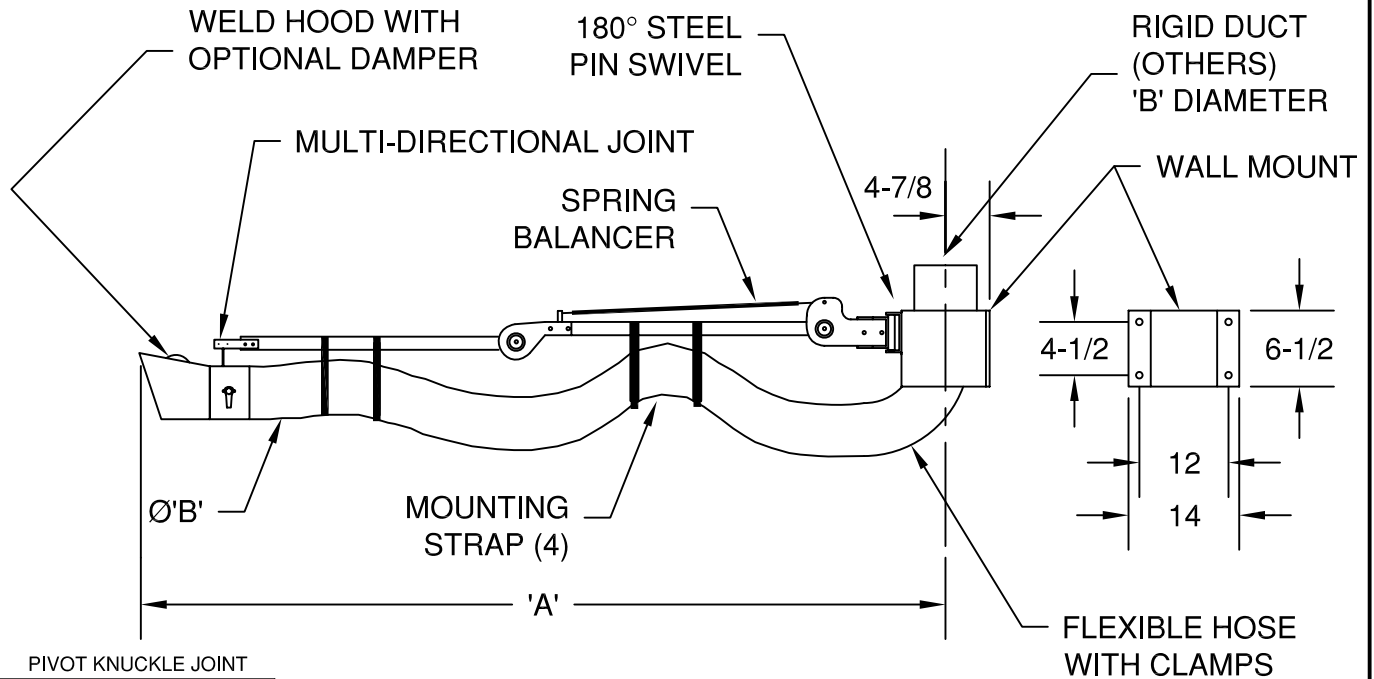

PIVOT KNUCKLE JOINT

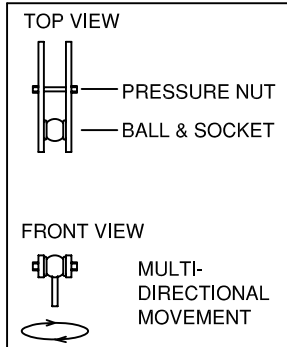

MODEL	'A'	'B'	MODEL	'A'	'B'
WAFE 4050	5'	4"	WAFE 4100	10'	4"
WAFE 5050	5'	5"	WAFE 5100	10'	5"
WAFE 6050	5'	6"	WAFE 6100	10'	6"
WAFE 8050	5'	8"	WAFE 8100	10'	8"
WAFE 4075	7-1/2'	4"			
WAFE 5075	7-1/2'	5"			
WAFE 6075	7-1/2'	6"			
WAFE 8075	7-1/2'	8"			

SCHEDULE

ITEM	QTY	MODEL	REFERENCE

NOTES:

ALL DIMENSIONS SHOWN IN INCHES.
 PLATFORM- 16 GA PAINTED STEEL. ARM TUBES- 1/8" WALL, SQUARE ALUMINUM. ARM JOINTS- 10 GA GALVANIZED STEEL. WALL MOUNT- HEAVY GA PAINTED STEEL. FLEXIBLE HOSE- MODEL NG NEOPRENE IMPREGNATED POLYESTER WITH GALVANIZED STEEL HELICAL SUPPORT. WELD HOOD- MODEL WH, 20 GA GALVANIZED STEEL. QUADRANT DAMPER AND/OR STAINLESS STEEL AND POLYCARBONATE CONSTRUCTION AVAILABLE. SPECIAL LENGTHS AND DIAMETERS MAY BE AVAILABLE UPON REQUEST.